

CAKOVEC

Marktsondierungsreise
Österreichisches

AußenwirtschaftsCenter Zagreb

9.4.2014

**Power from Biomass
by MAN TURBO
Steam Turbines**

Katarina Krkovic

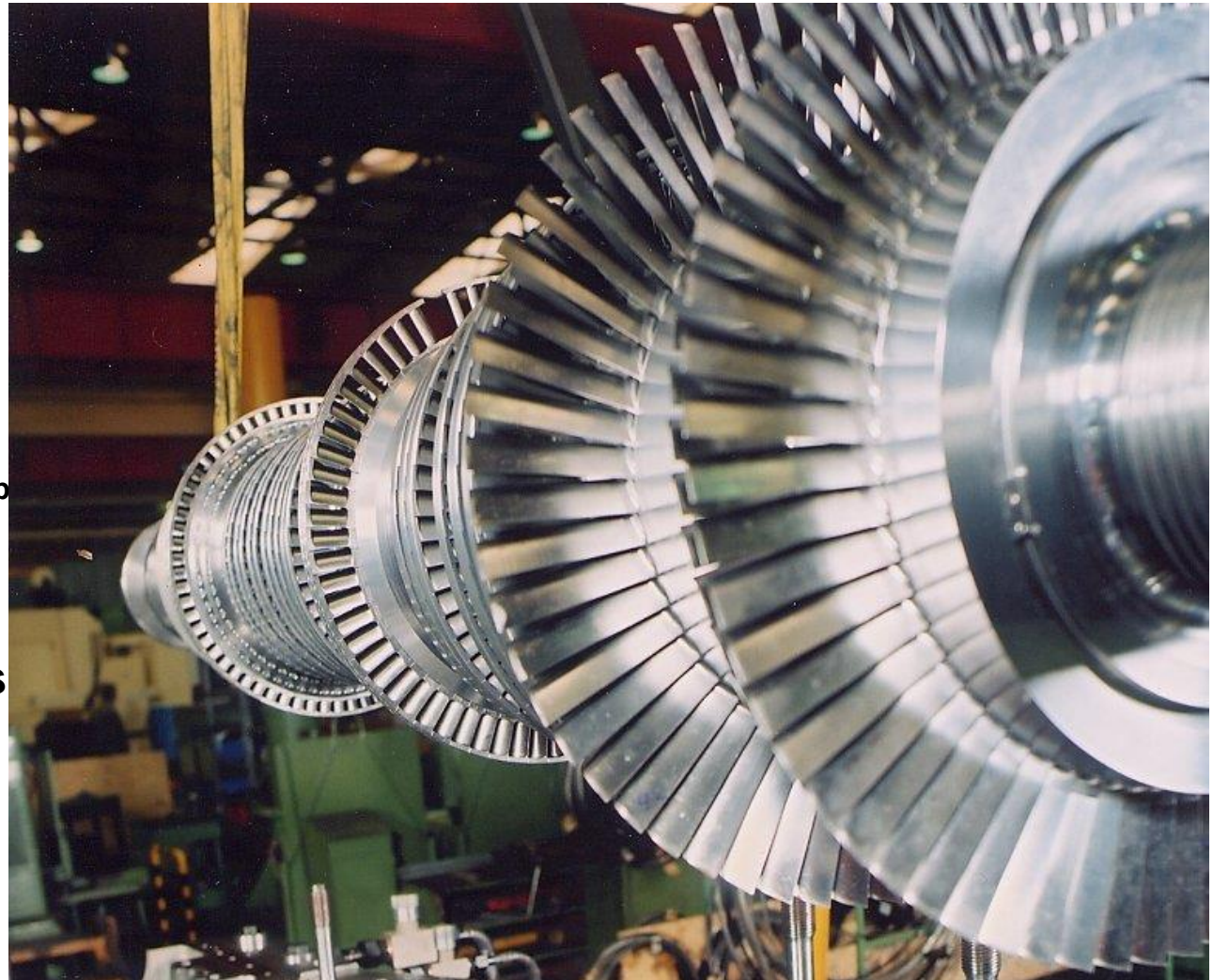

Modular Arrangement Concept

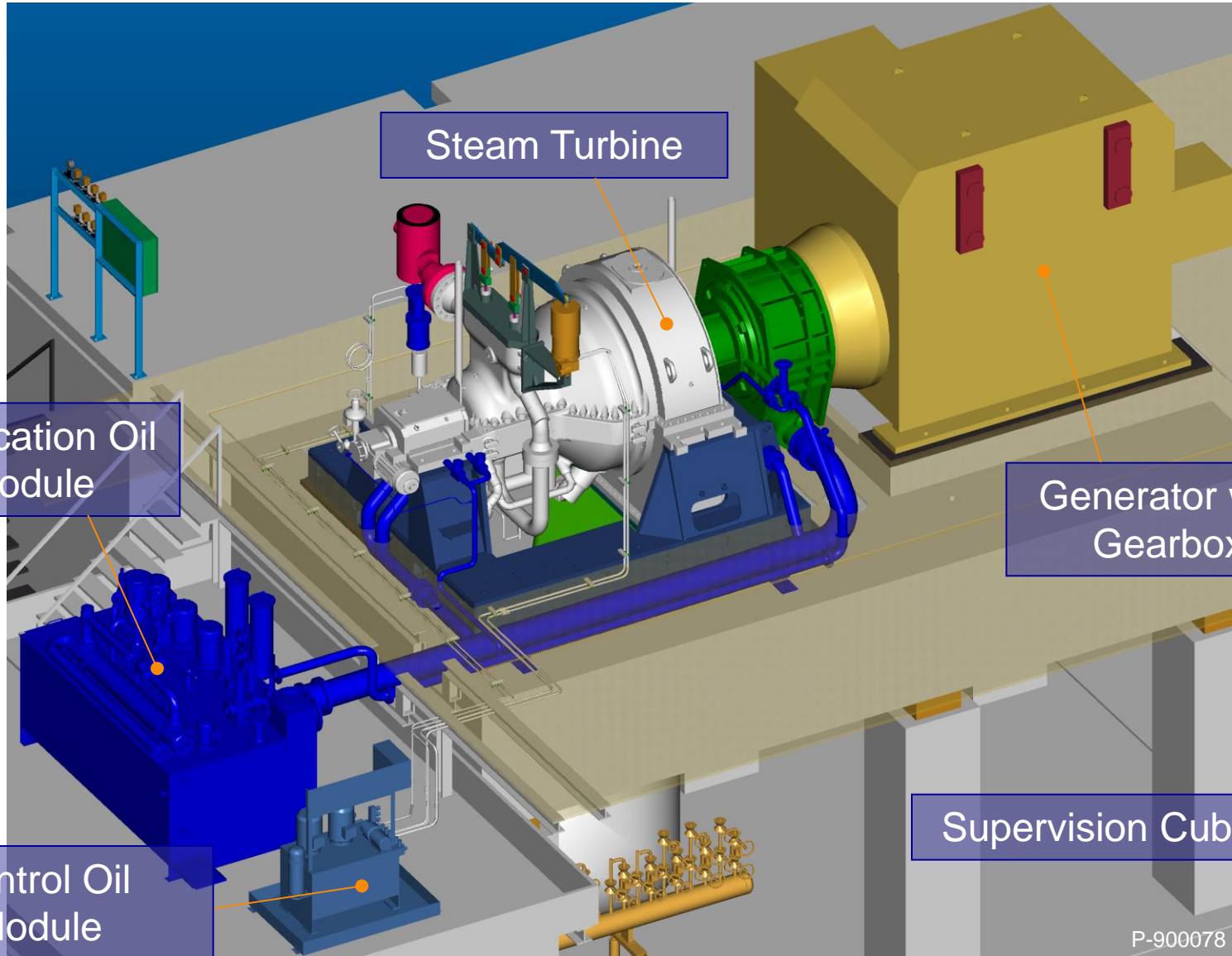

Example Extraction Turbine

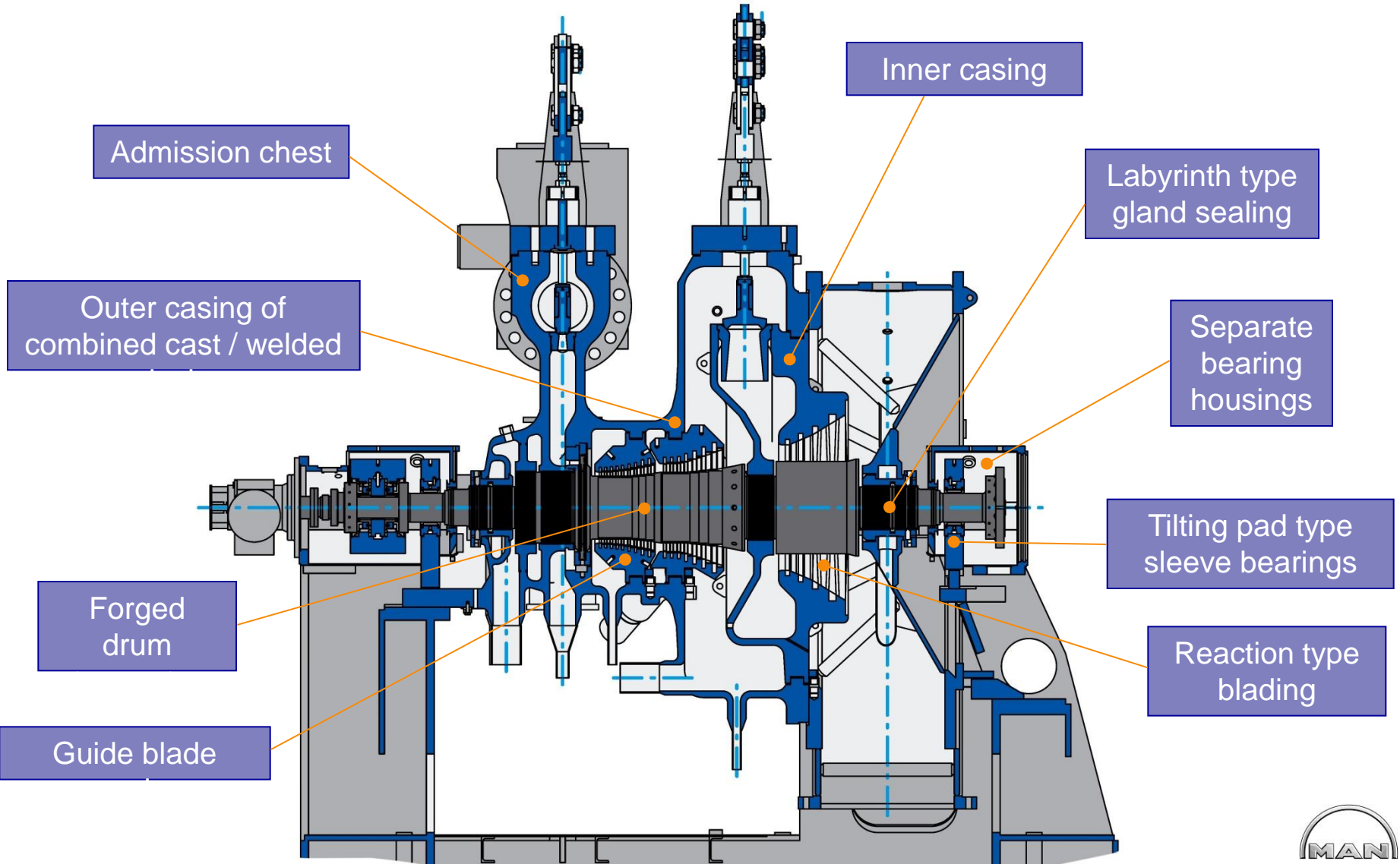

Generator with Gearbox



- Reduced oil consumption
- Low space demand

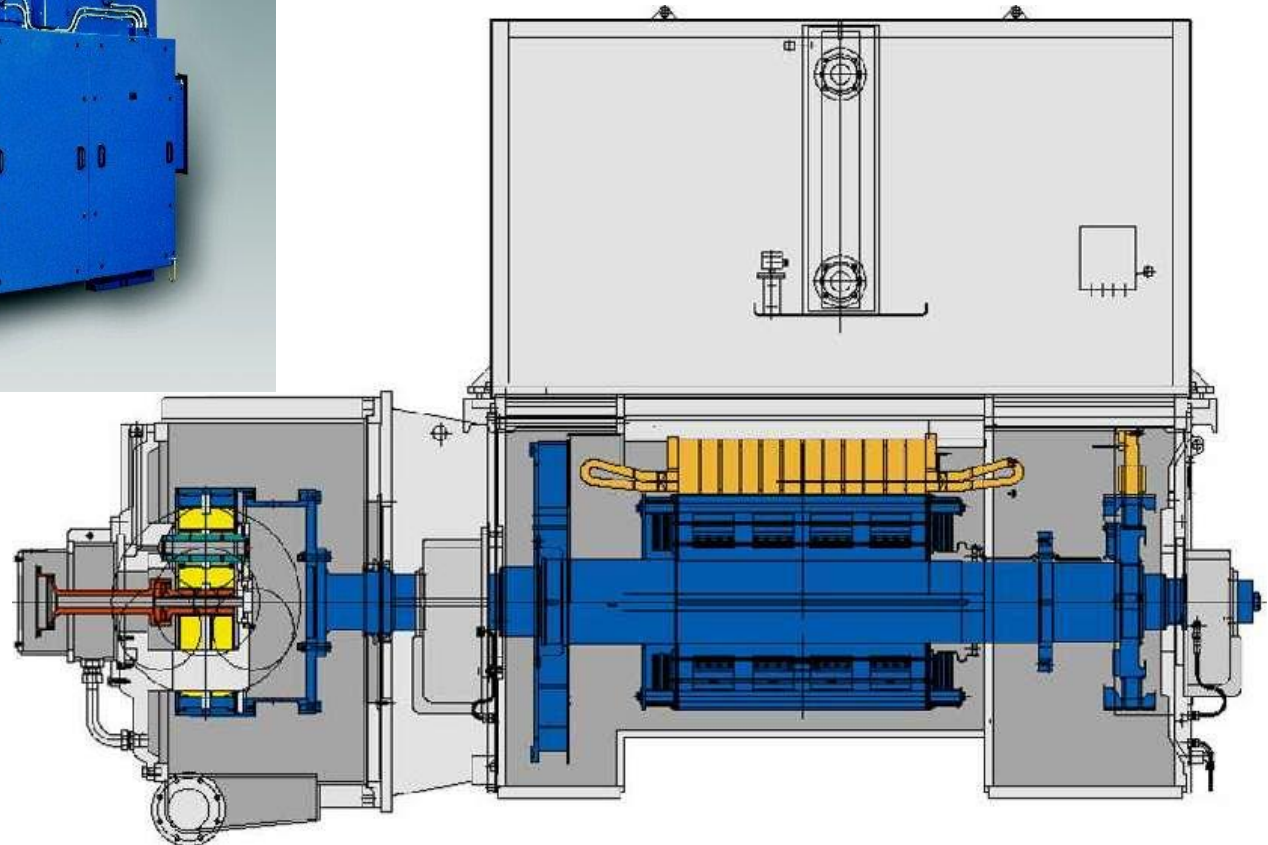

- High efficiency
- Low noise level



MARCTurbines Modular Arrangement Concept

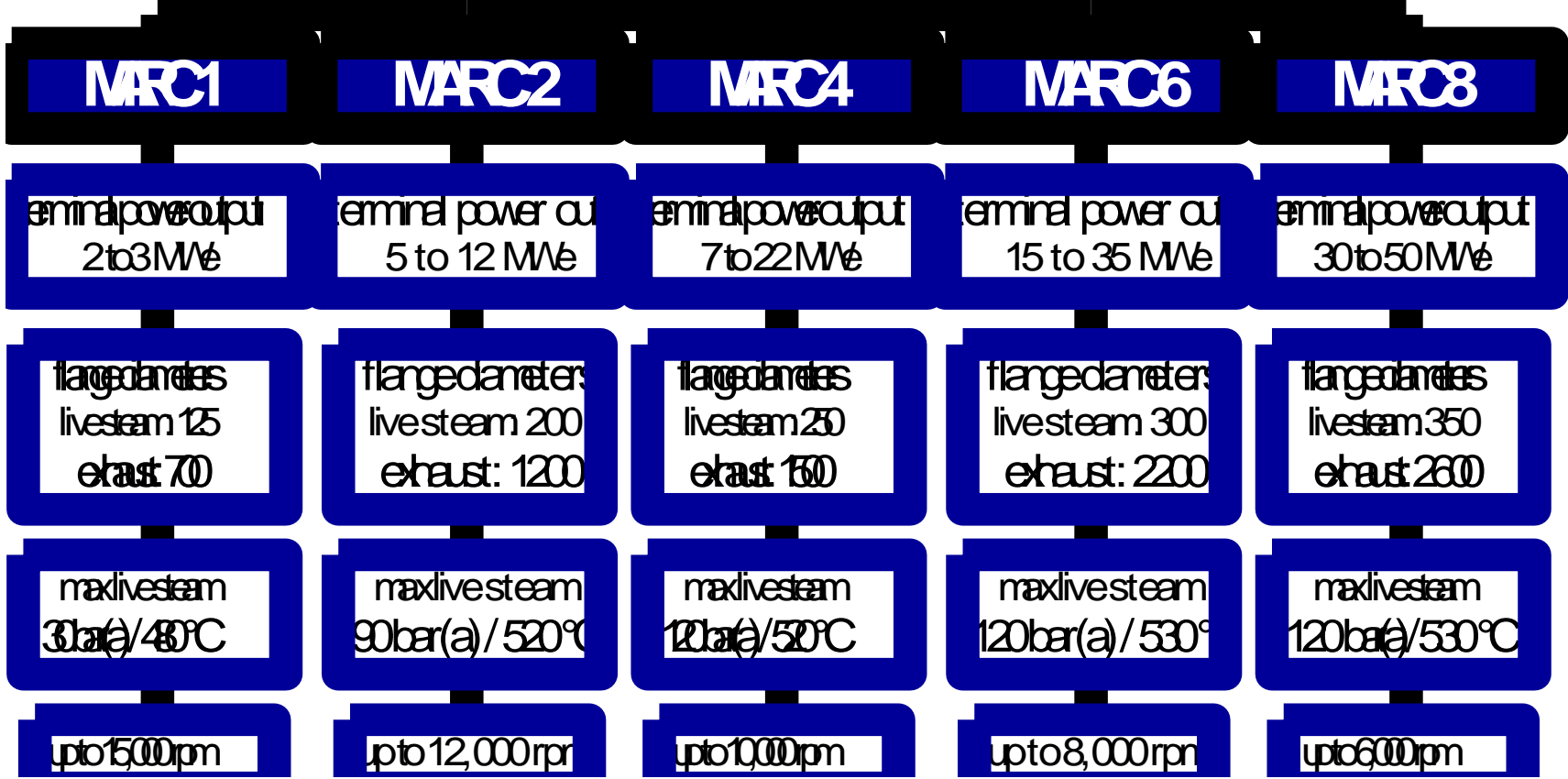



MARC Steam Turbines in the Field of Biomass

References in the past 5 years:

Over 200 steam turbines for
Biomass- Plants in Europe



Installed Power
from 2.3 to 23 MW_{el}

Issue
12/2006



MARC Turbines in Austria

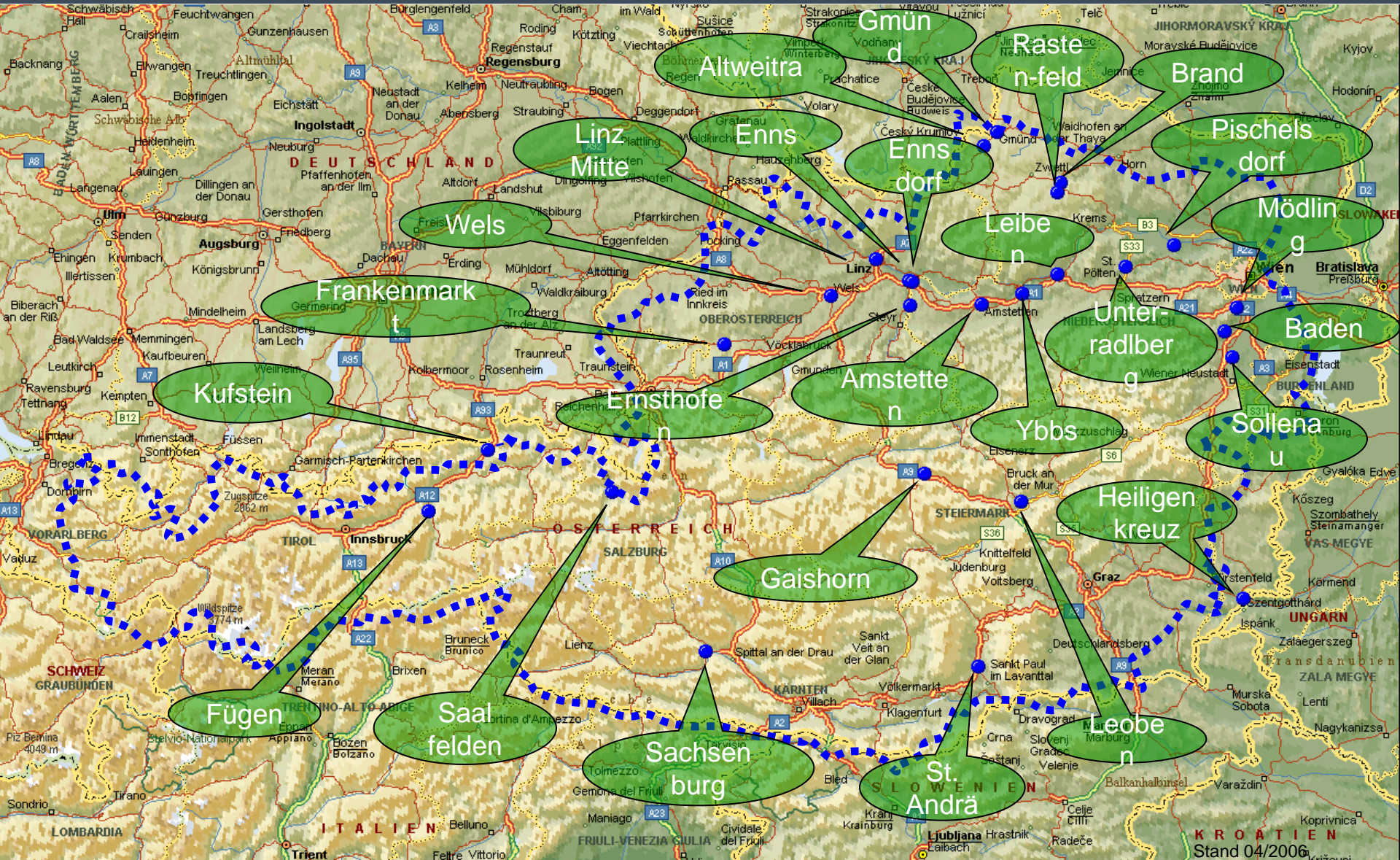

Characteristics of MARC Steam Turbines

- ✓ **High Efficiency**
- ✓ **High Availability**
- ✓ **Proven Design**
- ✓ **Low Investment Cost**

